

DIY GYM RUBBER INSTALLATION GUIDE

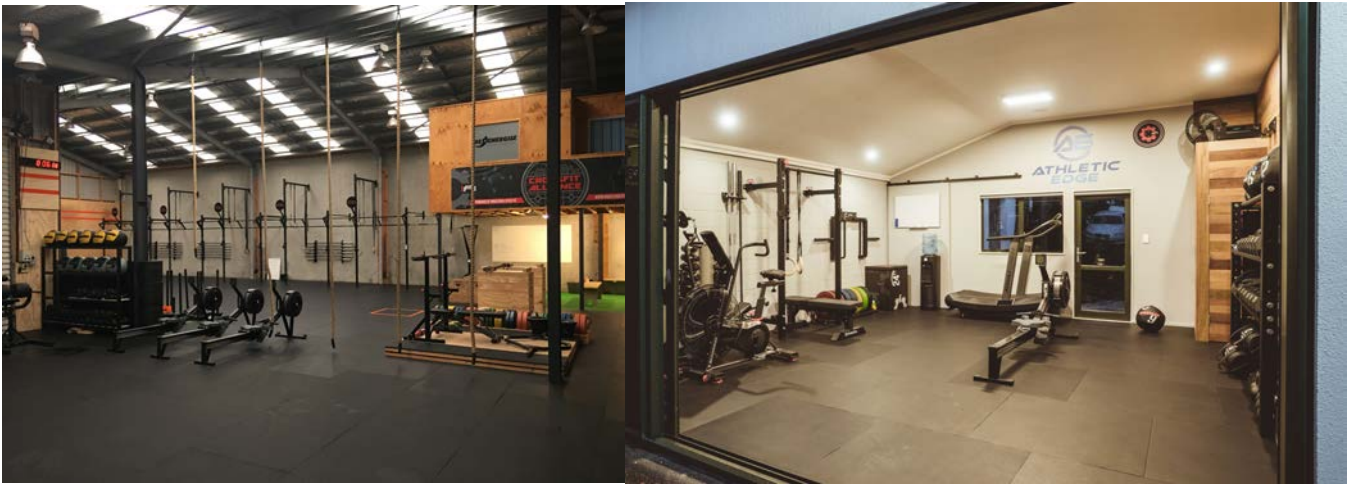









Installing your gym rubber flooring is not difficult and an average room can be completed in just a few hours after the necessary preparations have been completed. As with all DIY projects the end result depends upon using the right tools and methods from preparation to completion.

This Guide is intended to give you an understanding of the fundamentals of laying your Gym Rubber Tiles and give you some tips on how to get it right the first time.

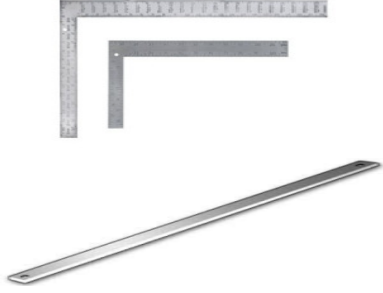
We will now attempt to explain to you the logical order for your project to proceed from start to finish.

Tools for the Job.

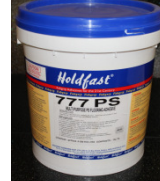
So you have gone to Carpet tiles 1 and purchased your Gym Rubber Tiles. What are some of the other essential items you should have on your shopping list? Consider this list:

 <p>A heavy duty utility knife or "Stanley knife" with extra brand new heavy duty blades.</p>	 <p>A solid scraper, heat gun and / or sanding equipment if you need to remove stubborn old glue.</p>	 <p>A metal straight edge to cut along (at least) or at best a straight metal edge with a right angle, like a "Try Square" that carpenters use</p>	 <p>A chalk line for finding and marking the centre of your room. (more on this later)</p>	
 <p>A marker pen.</p>	 <p>A wooden surface or dedicated cutting mat to cut and trim down your Gym Rubber tiles if needed.</p>	<p>(OPTIONAL)</p>  <p>1.5mm Notched Trowel If you are gluing down. (the above picture has bigger notches to illustrate only)</p>	 <p>Pressure Sensitive glue. - The specialised glue is an adhesive specifically suitable for Tiled Gym Rubber flooring</p>	 <p>For a professional finish it's worth hiring a roller from a hire company to bed the Rubber tiles to the glue properly.</p>

Surface Preparation.

Gym Rubber is easily laid over a variety of subfloor with very little preparation. The Nature of the desired activity on the floor, after completion, will dictate the strength of the subfloor requirements. Levelled, concrete floors are always the preferred subfloor. It is essential to have a relatively flat and damage free subfloor without holes. Normal expansion joints, concrete seams, or board joints will be no problem for the Gym Rubber tiles. However, If there are significant imperfections in the subfloor we recommend filling them and levelling them with a levelling compound



Whatever the surface you are laying on, all traces of old carpet, carpet gripping, nails or screws, old glue, dirt and grime must be removed completely. The floor surface should then be swept, mopped then vacuumed. .

Just like painting, time spent on initially preparing the surface that will be under your Gym Rubber tiles will ensure your end result. Take the extra time at this stage to ensure that your installation comes up to the best possible



- ❖ ***Fill any holes and nail in protruding nails in your floor. This should be completed at this stage so you end up with the optimal fresh clean flat surface to begin your job.***

Always allow your gym rubber tiles to acclimatise to their new environment before installing.

- ❖ *Now you have your sub-floor ready to lay over, you can start unpacking and acclimatising your tiles.*

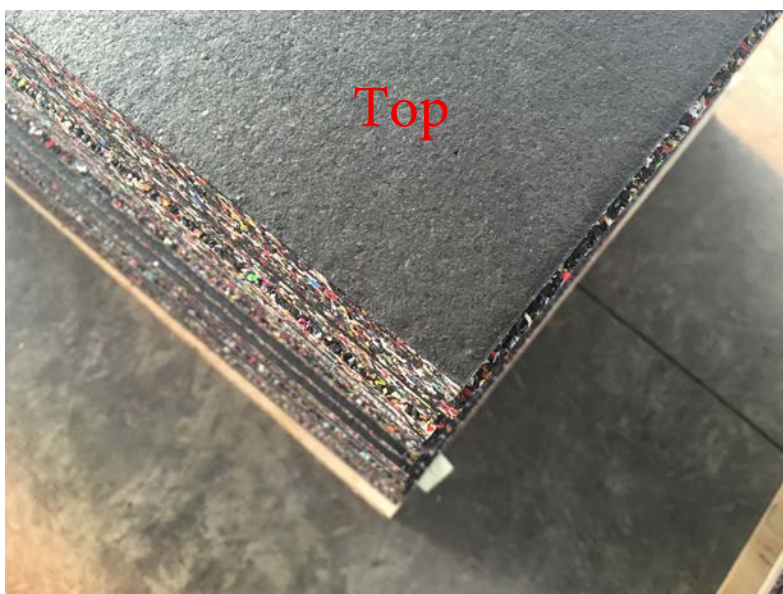

Rubber Tiles to **acclimatise** to your room. We recommend at least 72 hours of acclimatisation before laying. This will allow for expansion &/or contraction to the temperature at your location.

Remove them from the pallet and leave them to sit flat, spread around the room so they adapt to room conditions, heat, and humidity. This will ensure they all come to a consistent temperature.

It is worth giving serious planning and consideration to the design options available to you when laying your tiles.

As you will see on the following pages

there are several popular methods of laying out your tiles to create different design options.

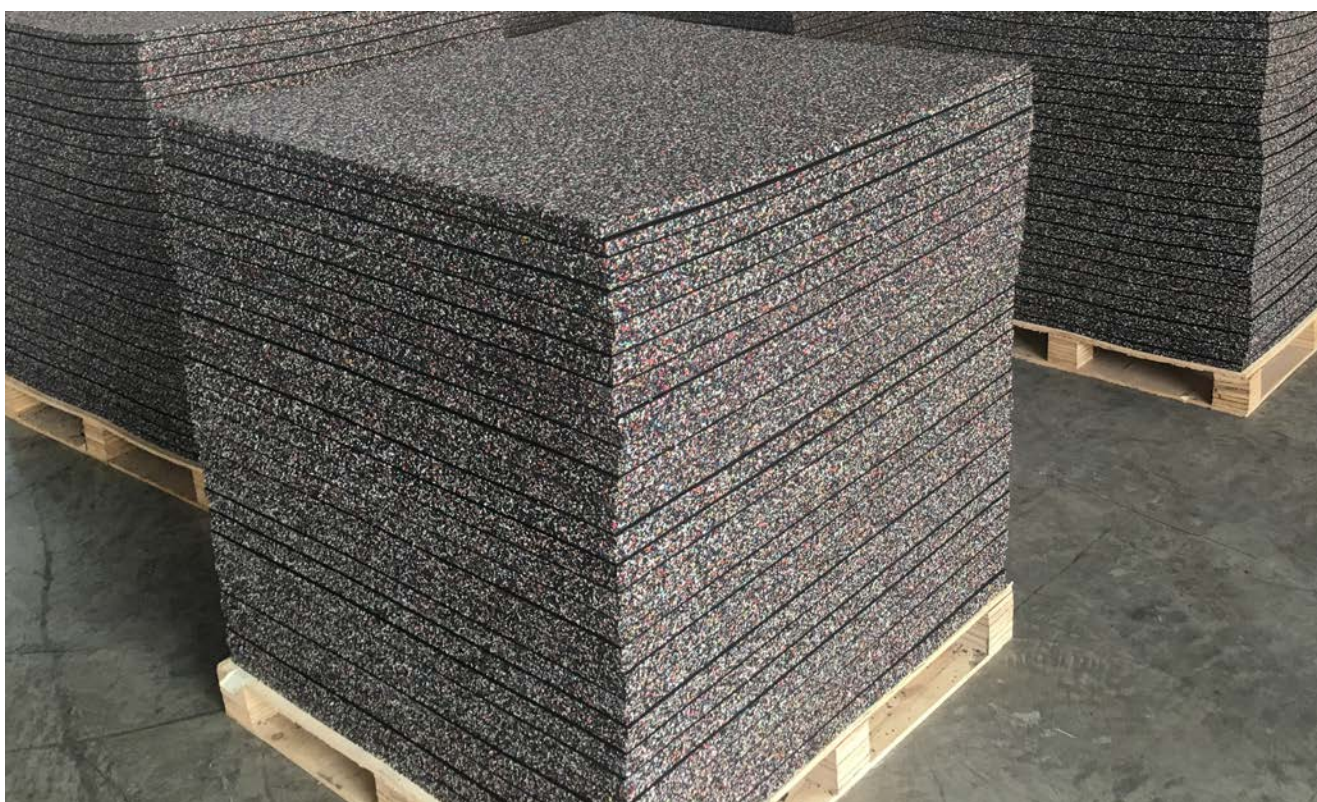

We recommend laying your tiles in "Brick Style" as shown below.

The rationale for this is that over any larger area you will get some variations in temperature which will cause some movement in the tiles over time. Brick style laying in gym rubber will minimise the subtle changes in appearance caused by movement, most effectively out of all of the installation methods covered below.

"Brick Style" –

This is where tiles are laid offset to create a stepped or staggered look.

Where a room is not perfectly square, this method is great to disguise the problem.

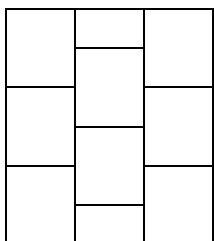

❖ **Find and Mark the middle of the room.**

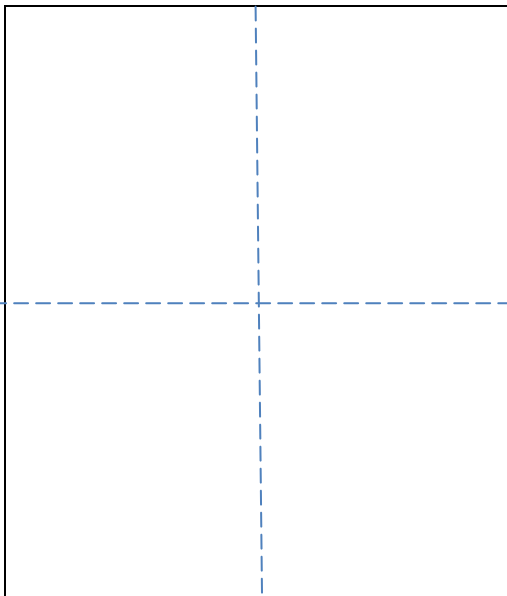

Using your chalk line its time to work out the centre of the room.

Measure along the length of your walls and mark the centre point of each of the walls.

It is important to measure each wall as often rooms are not exactly square and can be slightly out.

Position your chalk line and mark lines across the floor from side to side.

Doing this across all walls should end up with a cross point in the centre of the room. It is important that these lines are square as they will be the guide for all your future efforts. Take a moment and determine if they are square using the following methods.

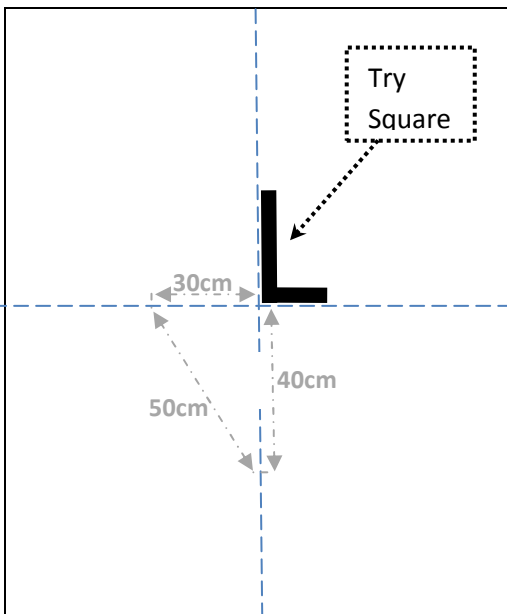

If you do have a “Try Square” available, use it to place along the lines and make sure they line up square.

If you do not have a Try Square, it is not a problem as there is a simple way to work out if your lines are square.

Using a tape or ruler, measure and mark from the cross point out 40 centimetres. Now measure and mark along the other line out from the cross point out 30 centimetres.

Finally measure from one mark to the other mark. The distance between the two should be 50cm.

If it is not 50cm or your try square does not line up with your lines on both sides, your lines and room are not square and your tiles will not line up exactly with the walls. It is very common for rooms to be slightly out from square so do not worry if this is the case.

Assuming that your room is not square, there are several techniques you can use to mark your start lines square.

Following on from above we will use the same techniques described above to measure out points and mark lines that are square.

❖ **Squaring up your guide lines.**

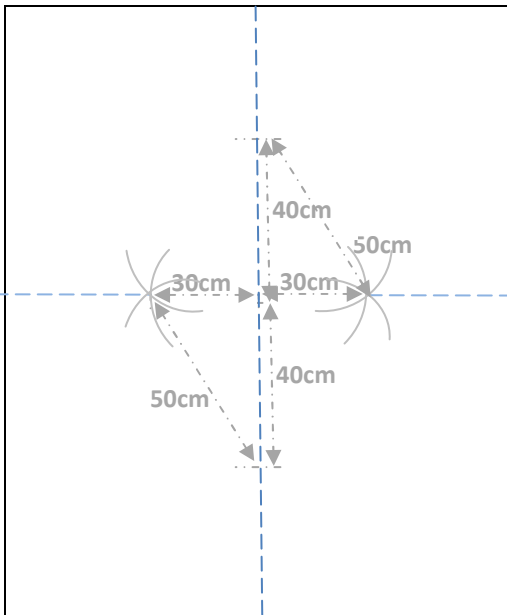

Without a try Square:

Pick the opposite walls where the length of the walls is the closest, and use the chalk line from the centre of those walls to be your starting point.

Now that we know the centre point of that line (from the step above) measure back up that line 40cm on each side of the centre point.

From each of these points 40cm off centre, measure out 50cm and mark a small curve at 50cm from each of these points.

Next measure 30cm each side of the centre point and mark a small curve at 30cm from the centre point.

Finally line your chalk line to mark a straight line from one wall through the point where the three arcs meet, then through the centre point on the middle line, then through the other meeting point of the arcs on the other side, and finally out to the wall on the other side.

If done correctly, these lines will now be square and you are ready to progress to the next step.

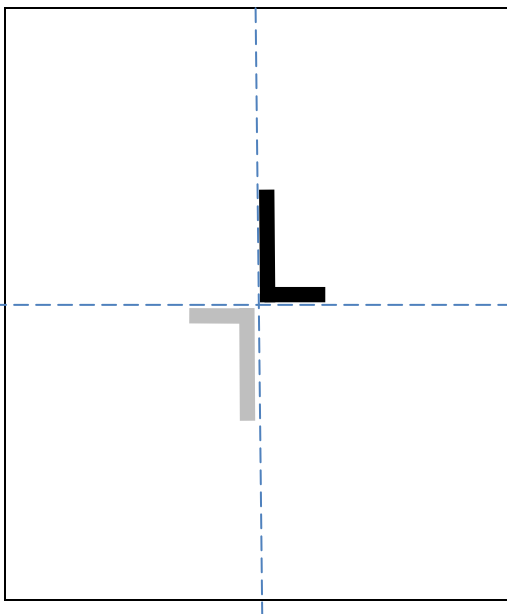

With a try Square:

If you have your try square, place the point of it at the centre point where the lines cross. Mark out the points each side from the end of the other arm of the try square. Do the same measuring the other side of the centre line.

Using your chalk line to then mark lines that go straight through the centre point where the lines cross and through the point where your points each side were marked using the try square and extend the new chalk line out to the walls each side.

If done correctly, these lines will now be square and you are ready to progress to the next step.

❖ **Lay your tiles.**

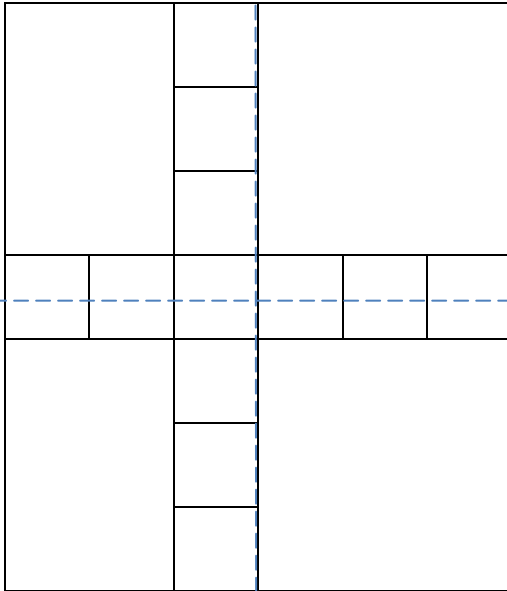

Taking your loose tiles, start at the centre and loose lay then out from the centre and work out the best fit for your room.

Determine if you are better laying your tiles along the centre line, or down the middle of the centre line.

Lay tiles out from the centre and work out how many to each wall, and determine if you will need to trim tiles to fit to your room.

In the example to the left, if we laid the vertical centre row with the tile edge along the centre line, then we would need to cut each tile at the top and bottom in half to fit the room.

It is best to take the time now and plan out what looks best for your circumstances.

❖ **Laying your tiles using Glue.**

Ensuring that your floor is still clean and prepared in line with the instructions on the previous pages,

If you require adhesive, use a flat trowel or a roller, and apply the glue to the floor. When doing larger areas, focus on laying one section at a time then move on to the next section.

Make sure you keep the area well ventilated while you are gluing tiles.

Follow the specific instructions for the glue you intend to use.

When the adhesive first goes Allow it to tack off, making it workable, but not dry and ready to lay the tiles. When the glue is ready, begin laying tiles

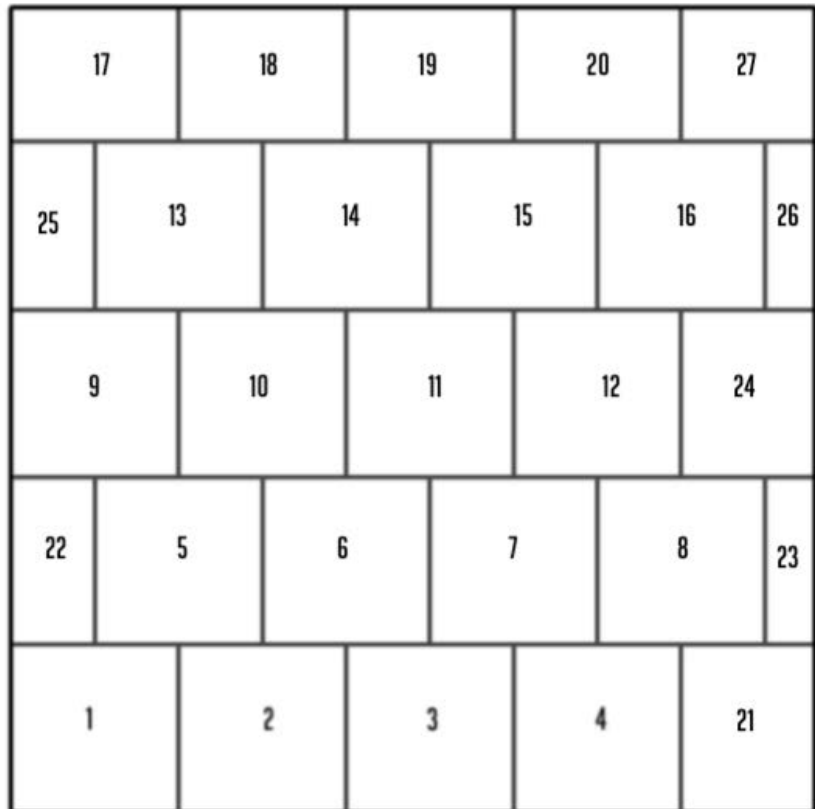

This generally takes between 15-30 minutes depending upon climate in the room.

It is usually best to lay along the shorter span of the room in a linear fashion. For the purpose of this instruction, we have placed an X and Y axis on the diagram above.

Start by laying across one wall, preferably a side that requires no cutting of tiles. Continue laying your Gym Rubber tiles, working out from the corner along a single axis, and placing tiles up to the wall or surrounding tiles, squaring them snug to the surrounding tiles as you go.

If the tiles next to the wall need to be cut or trimmed to fit to the wall, cut them per the instructions at the end of the guide, to maintain the other sides square.

In each row, every 3-5 tiles, create an overlap of 5mm. These will be the last tiles to insert as they will compress the entire row.

Continue laying until you finish your section, then lay glue in the next section and continue in a similar fashion. Lay all tiles that you can lay as full tiles, leaving out difficult tiles, then once all full tiles are down, move on to trimming and cutting tiles to fit remaining gaps and around pillars and other obstacles.

Please note that you can either follow the above numbering to lay to glue, do a quarter of the room then move to the next quarter of the room.

In some installations you may also need to start from an access point like a doorway and line up to that, however you should always measure and plan from the centre point of the room.

❖ **Cutting your tiles to walls and obstacles.**

Where you need to cut your tiles to fit between walls and the remaining tiles, or around obstacles in the room it is best to measure twice cut once. Remember to make sure that you take care cutting the back of the tiles.

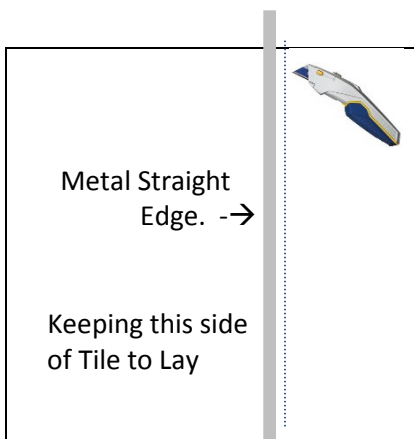
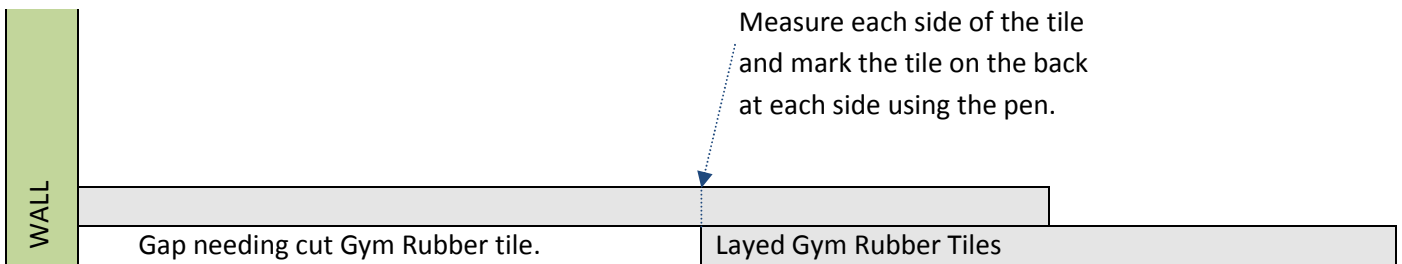

Get your marked tile and put it face up, on the cutting mat or board.

Line up your metal straight edge or T-square between the two marks towards the side that will be laid so that if you accidentally make a mistake it will not affect the portion that will get laid on the floor.

Use your Utility knife or Stanley knife to cut a straight line in the “surface wear” layer along the metal straight edge.

The surface wear layer is the top layer of the tiles, not the underside.

Be very careful to take it slow so that your knife does not wander away from the straight edge. Cut and fit your tile, then move on to repeat the process for the remaining tiles.

Where you have poles pillars and other obstacles, Measure out where you need to cut your tiles and follow the above instructions in a similar fashion. Always remember it is better to cut out less tile than more as you can trim it down to fit in better, whereas if you cut out too much you will then have a gap or have to cut other slivers of tile to infill the mistake.

❖ **Roll the Gym Rubber Tiles (Optional).**

As a final step, consider using a roller to bed the Gym Rubber tiles down into the glue. Rollers can be hired from most equipment hire businesses for reasonable prices. This will ensure that your Gym Rubber tiles properly bond to the pressure sensitive glue, remove any air bubbles and remain in place and stuck down for years to come.

❖ **Apply Gym Rubber Sealer (Optional).**

Depending upon your ventilation, you may wish to apply a Gym Rubber Sealant to your tiles.

Some of the advantages of a sealant are that it adds a sacrificial layer to your tiles, helps seal in VOC Gases from the rubber binder, and assists in repelling water, moisture and sweat from your tiles.

